

In-Sight[®] Micro Series Vision System Installation Manual



2024 October 10
Revision: 6.5.1.3

Legal Notices

The software described in this document is furnished under license, and may be used or copied only in accordance with the terms of such license and with the inclusion of the copyright notice shown on this page. Neither the software, this document, nor any copies thereof may be provided to, or otherwise made available to, anyone other than the licensee. Title to, and ownership of, this software remains with Cognex Corporation or its licensor. Cognex Corporation assumes no responsibility for the use or reliability of its software on equipment that is not supplied by Cognex Corporation. Cognex Corporation makes no warranties, either express or implied, regarding the described software, its merchantability, non-infringement or its fitness for any particular purpose.

The information in this document is subject to change without notice and should not be construed as a commitment by Cognex Corporation. Cognex Corporation is not responsible for any errors that may be present in either this document or the associated software.

Companies, names, and data used in examples herein are fictitious unless otherwise noted. No part of this document may be reproduced or transmitted in any form or by any means, electronic or mechanical, for any purpose, nor transferred to any other media or language without the written permission of Cognex Corporation.

Copyright © 2008 - 2020. Cognex Corporation. All Rights Reserved.

Portions of the hardware and software provided by Cognex may be covered by one or more U.S. and foreign patents, as well as pending U.S. and foreign patents listed on the Cognex web site at: cognex.com/patents.

The following are registered trademarks of Cognex Corporation:

Cognex, 2DMAX, Advantage, AlignPlus, Assemblyplus, Check it with Checker, Checker, Cognex Vision for Industry, Cognex VSOC, CVL, DataMan, DisplayInspect, DVT, EasyBuilder, Hotbars, IDMax, In-Sight, Laser Killer, MVS-8000, OmniView, PatFind, PatFlex, PatInspect, PatMax, PatQuick, SensorView, SmartView, SmartAdvisor, SmartLearn, UltraLight, Vision Solutions, VisionPro, VisionView

The following are trademarks of Cognex Corporation:

The Cognex logo, 1DMax, 3D-Locate, 3DMax, BGAll, CheckPoint, Cognex VSoC, CVC-1000, FFD, iLearn, In-Sight (design insignia with cross-hairs), In-Sight 2000, InspectEdge, Inspection Designer, MVS, NotchMax, OCRMax, PatMax RedLine, ProofRead, SmartSync, ProfilePlus, SmartDisplay, SmartSystem, SMD4, VisiFlex, Xpand

Portions copyright © Microsoft Corporation. All rights reserved.

Portions copyright © MadCap Software, Inc. All rights reserved.

Other product and company trademarks identified herein are the trademarks of their respective owners.

Regulations/Conformity

i **Note:** For the most current CE and UKCA declaration and regulatory conformity information, see the Cognex support site: cognex.com/support.

Declaration of Conformity	
Manufacturer	Cognex Corporation One Vision Drive Natick, MA 01760 USA
CE	In-Sight Micro 1020/1050/1100/1110/1400/1410: Type 821-0043-1R In-Sight Micro 1100C/1400C: Type 821-0044-1R In-Sight Micro 1402/1412: Type 821-0078-1R In-Sight Micro 1403/1413: Type 821-0047-1R In-Sight Micro 1403C: Type 821-0048-1R In-Sight Micro 1500: Regulatory Model 1AAN This is a class A product. In a domestic environment this product may cause radio interference in which case the user may be required to take immediate measures. This equipment complies with the essential requirements of the EU Directive 2014/30/EU. Declarations are available from your local representative.
EU RoHS	Compliant to the most recent applicable directive.
FCC	FCC Part 15, Class A This equipment has been tested and found to comply with the limits for a Class A digital device, pursuant to part 15 of the FCC Rules. These limits are designed to provide reasonable protection against harmful interference when the equipment is operated in a commercial environment. This equipment generates, uses, and can radiate radio frequency energy and, if not installed and used in accordance with the instruction manual, may cause harmful interference to radio communications. Operation of this equipment in a residential area is likely to cause harmful interference in which case the user will be required to correct the interference at his own expense.
Korea 	In-Sight Micro 1020/1050/1100/1110/1400/1410: CGX-ISM1400-00(A) In-Sight Micro 1100C/1400C: CGX-ISM1400-C00(A) In-Sight Micro 1402/1412: KCC-REM-CGX-ISM1402-01 In-Sight Micro 1403/1413: CGX-ISM1403-00(A) In-Sight Micro 1403C: CGX-ISM1403-C00(A) In-Sight Micro 1500: Regulatory Model 1AAN: MSIP-REM-CGX-1AAN This device is certified for office use only and if used at home, there can be frequency interference problems.
TÜV	In-Sight Micro 1020/1050/1100/1110/1400/1410: Type 821-0043-1R In-Sight Micro 1100C/1400C: Type 821-0044-1R In-Sight Micro 1402/1412: Type 821-0078-1R In-Sight Micro 1403/1413: Type 821-0047-1R In-Sight Micro 1403C: Type 821-0048-1R In-Sight Micro 1500: Regulatory Model 1AAN NRTL: TÜV SÜD AM SCC/NRTL OSHA Scheme for UL/CAN 60950-1. CB report available upon request. TÜV SÜD AM, IEC/EN 60950-1.

For European Community Users

Cognex complies with Directive 2012/19/EU OF THE EUROPEAN PARLIAMENT AND OF THE COUNCIL of 4 July 2012 on waste electrical and electronic equipment (WEEE).

This product has required the extraction and use of natural resources for its production. It may contain hazardous substances that could impact health and the environment, if not properly disposed.

In order to avoid the dissemination of those substances in our environment and to diminish the pressure on the natural resources, we encourage you to use the appropriate take-back systems for product disposal. Those systems will reuse or recycle most of the materials of the product you are disposing in a sound way.



The crossed out wheeled bin symbol informs you that the product should not be disposed of along with municipal waste and invites you to use the appropriate separate take-back systems for product disposal.

If you need more information on the collection, reuse, and recycling systems, please contact your local or regional waste administration.

You may also contact your supplier for more information on the environmental performance of this product.

Precautions

To reduce the risk of injury or equipment damage, observe the following precautions when you install the Cognex product:

- An IEEE 802.3af compliant, and UL or NRTL listed, Power over Ethernet (PoE) power source rated Class 0, 2, 3 or 4 must be used. Any other voltage creates a risk of fire or shock and can damage the components. Applicable national and local wiring standards and rules must be followed.
- This product is intended for industrial use in automated manufacturing or similar applications.
- The safety of any system incorporating this product is the responsibility of the assembler of the system.
- Route cables and wires away from high-current wiring or high-voltage power sources to reduce the risk of damage or malfunction from the following causes: over-voltage, line noise, electrostatic discharge (ESD), power surges, or other irregularities in the power supply.
- Do not install Cognex products where they are exposed to environmental hazards such as excessive heat, dust, moisture, humidity, impact, vibration, corrosive substances, flammable substances, or static electricity.
- Do not expose the image sensor to laser light. Image sensors can be damaged by direct, or reflected, laser light. If your application requires laser light that might strike the image sensor, use a lens filter at the corresponding laser wavelength. For suggestions, contact your local integrator or application engineer.
- This product does not contain user-serviceable parts. Do not make electrical or mechanical modifications to product components. Unauthorized modifications can void your warranty.
- Changes or modifications not expressly approved by the party responsible for regulatory compliance could void the user's authority to operate the equipment.
- Include service loops with cable connections.
- Ensure that the cable bend radius begins at least six inches from the connector. Cable shielding can be degraded or cables can be damaged or wear out faster if a service loop or bend radius is tighter than 10X the cable diameter.
- This device should be used in accordance with the instructions in this manual.

Table of Contents

Legal Notices	2
Regulations/Conformity	3
For European Community Users	4
Precautions	5
Table of Contents	6
Introduction	7
Support	7
Standard Components	7
Cables	8
Ethernet Cable	8
Breakout Cable	9
I/O Module Cable	9
Installation	10
Connectors and Indicators	10
Install the Mounting Block (Optional)	11
Install the Lens	11
Connect the Inputs and Outputs (Optional)	12
Option 1: Connect the Breakout Cable	12
Option 2: Connect the I/O Module Cable	13
Connect the Ethernet and Power	14
Connect the Power Wires	14
Connect the Frame Ground Wire	15
Connect an RJ-45 LAN Cable	16
Connect the Ethernet Cable	16
Specifications	18
In-Sight Micro Vision System Specifications	18
I/O Specifications	21
Acquisition Trigger Input	21
High-Speed Outputs	22
High-Speed Output - NPN Configuration	23
High-Speed Output - PNP Configuration	23
High-Speed Output - Relay/LED Configuration	24
Ethernet Cable Specifications	25
Breakout Cable Specifications	26
I/O Module Cable Specifications	27
Dimensions	28
Vision System Dimensions	28
Vision System Dimensions (with Mounting Block)	29
Appendix A - Cleaning and Maintenance	30
Clean the Vision System Housing	30
Clean the Vision System Image Sensor Window	30

Introduction

The In-Sight[®] vision system is a compact, network-ready, stand-alone machine vision system used for automated inspection, measurement, identification and robot guidance applications on the factory floor. All models can be easily configured remotely over a network using an intuitive user interface.

Support

Many information resources are available to help you use the vision system:

- The *In-Sight[®] Explorer Help* and *EasyBuilder Help* files, provided with In-Sight Explorer software.
- On-demand training: cognex.com/on-demand-training.aspx.
- The In-Sight online support site: cognex.com/support/insight.

Note: For the latest documentation, visit: support.cognex.com/documentation/in-sight.

Standard Components

In-Sight Micro vision system is shipped with the following standard components.

Component	Description
Vision System	Provides image acquisition, vision processing, job storage, Ethernet connectivity and discrete I/O.
Mounting Kit	Includes M3 screws for mounting the vision system (quantity 4) and an optional mounting block for securing the vision system to a mounting surface.
Extension Ring	A 5mm extension ring (for use with C-mount lenses).

Cables

Note: Cables are sold separately.

CAUTION: All cable connectors are keyed to fit the connectors on the vision system. Do not force the connections or damage may occur.

Ethernet Cable

The Ethernet cable provides the Ethernet connection for network communications and supplies power to the vision system. The pin-outs for the cable are listed in the [Ethernet Cable Specifications on page 25](#). This cable is available in the lengths and styles listed below.

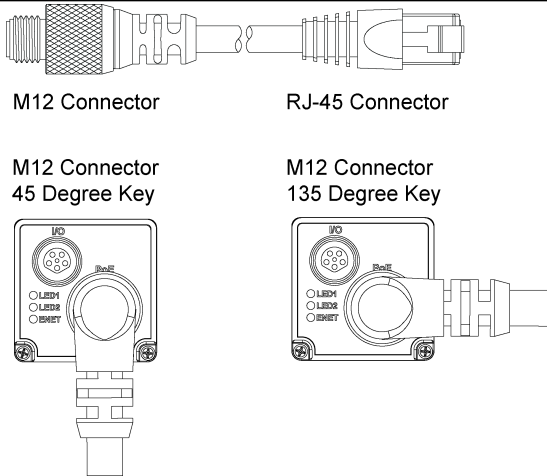
			
Length	Standard Part #	45-Degree Key Right-Angle Part #	135-Degree Key Right Angle Part #
0.6 m	CCB-84901-1001-00	N/A	N/A
2 m	CCB-84901-1002-02	CCB-84901-6005-02	CCB-84901-7005-02
5 m	CCB-84901-1003-05	CCB-84901-6001-05	CCB-84901-7001-05
10 m	CCB-84901-1004-10	CCB-84901-6002-10	CCB-84901-7002-10
15 m	CCB-84901-1005-15	CCB-84901-6003-15	CCB-84901-7003-15
30 m	CCB-84901-1006-30	CCB-84901-6004-30	CCB-84901-7004-30

Breakout Cable

The Breakout cable provides access to the vision system's trigger and high-speed outputs. The Breakout cable can be connected to devices, such as a PLC, trigger sensor or strobe light. The pin-outs for the cable are listed in the [Breakout Cable Specifications on page 26](#). This cable is available in the lengths listed below.

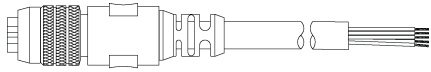
 M8 Connector	
Length	Part #
0.6 m	CCB-M8IO-00
2 m	CCB-M8IO-02
5 m	CCB-M8IO-05
10 m	CCB-M8IO-10
15 m	CCB-M8IO-15

I/O Module Cable

The I/O Module cable is used with the CIO-MICRO or CIO-MICRO-CC I/O module. The I/O Module cable connects the vision system directly to the I/O module via the DB15 connector. When connected, the I/O Module cable provides access to the vision system's trigger and high-speed outputs. The pin-outs for the cable are listed in the [I/O Module Cable Specifications on page 27](#). This cable is available in the lengths listed below.

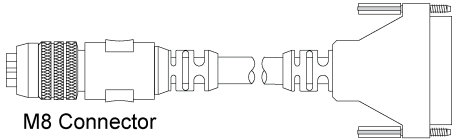
 M8 Connector DB15 Connector	
Length	Part #
0.7 m	CCB-M8DSIO-00
2 m	CCB-M8DSIO-02
5 m	CCB-M8DSIO-05
10 m	CCB-M8DSIO-10
15 m	CCB-M8DSIO-15

Installation

Read this section to learn how the vision system connects to its standard components and accessories. For a list of options and accessories, contact your Cognex sales representative.

Note:

- Cables are sold separately.
- If a standard component is missing or damaged, immediately contact your Cognex Authorized Service Provider (ASP) or Cognex Technical Support.

Connectors and Indicators

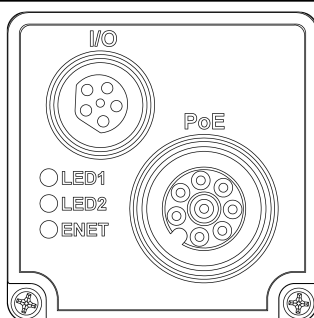

Connector/Indicator	Function
I/O Connector	Provides connections to the acquisition trigger input and high-speed outputs.
PoE Connector	Provides the Ethernet connection for network communications and supplies power to the vision system.
LED1	Green when active. User-configurable using Discrete Output Line 4 (Line 10 when using the CIO-MICRO or CIO-MICRO-CC I/O module).
LED2	Red when active. User-configurable using Discrete Output Line 5 (Line 11 when using the CIO-MICRO or CIO-MICRO-CC I/O module).
ENET	100-BaseT: Red when the vision system is receiving power during startup, momentarily switches to green when a network connection is established, and then blinks green when network traffic is detected. If a network connection cannot be established, the LED remains red. 10-BaseT: Red when the vision system is receiving power during startup, momentarily switches to green when a network connection is established. The LED is solid green with red blinking when network traffic is detected. If a network connection cannot be established, the LED remains red.

Install the Mounting Block (Optional)

The mounting kit includes a mounting bracket and M3 screws (quantity 4) for mounting the vision system and securing it to a mounting surface. The mounting bracket also has 1/4 - 20 and M6 mounting holes available for mounting the vision system to a mounting surface. For more information, refer to [Vision System Dimensions on page 28](#).

1. Align the mounting block with the mounting holes on the vision system.
2. Insert the M3x6 (quantity 4) screws into the mounting holes and tighten the screws using a 2.5mm hex wrench; the maximum torque is 0.9039 Nm (8 in-lb).

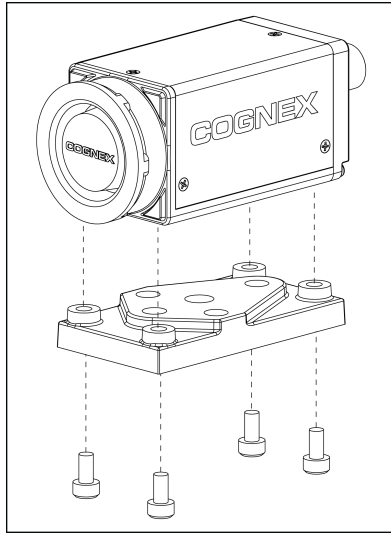

Install the Lens

1. Remove the protective film covering the threaded lens opening, if present.
2. Attach a CS-Mount or C-Mount (with 5mm extension ring) lens to the vision system. The exact lens focal length needed depends on the working distance and the field of view required for your machine vision application.

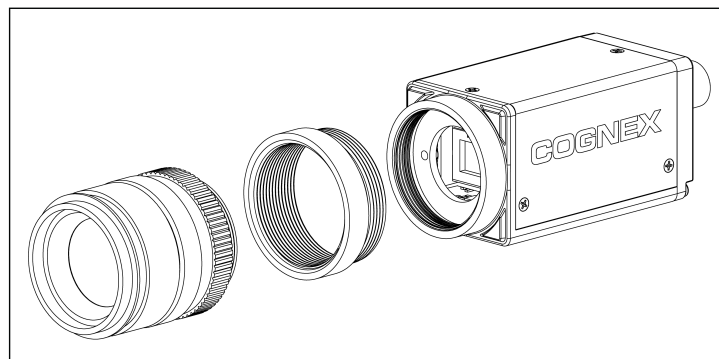

Connect the Inputs and Outputs (Optional)

The vision system's I/O connector supplies connections for the acquisition trigger and high-speed outputs.

CAUTION: All cable connectors are keyed to fit the connectors on the vision system. Do not force the connections or damage may occur.

Note:



- I/O wiring or adjustments to I/O devices should be performed when the vision system is not receiving power.
- The vision system must be Online for the discrete inputs and outputs to function.
- Refer to the *In-Sight® Explorer Help* file for details on configuring the discrete input and output lines.

Option 1: Connect the Breakout Cable



Note: You can clip unused wires short or use a tie made of non-conductive material to tie them back.

1. Connect the Breakout cable's M8 connector to the vision system's I/O connector.
2. Connect the trigger and high-speed I/O wires to an appropriate device (for example, a PLC, trigger sensor or strobe light). For more information, refer to [Breakout Cable Specifications on page 26](#).

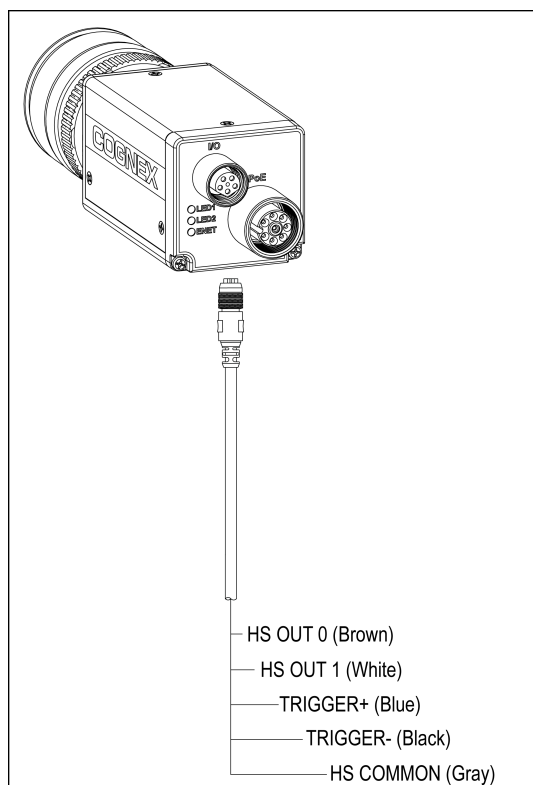

Option 2: Connect the I/O Module Cable

1. Connect the I/O Module cable's M8 connector to the vision system I/O connector.

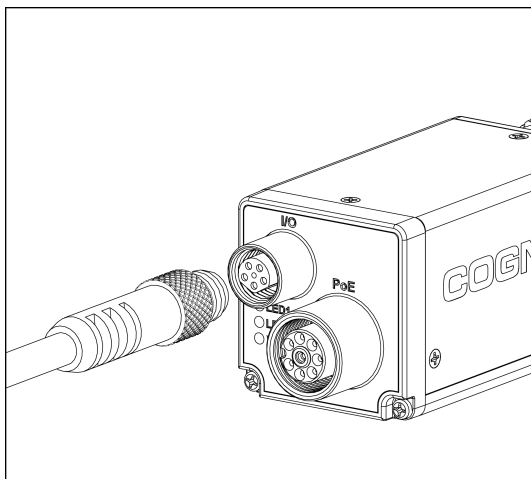

2. Connect the I/O Module cable's DB15 connector to the I/O module's I/O connector.

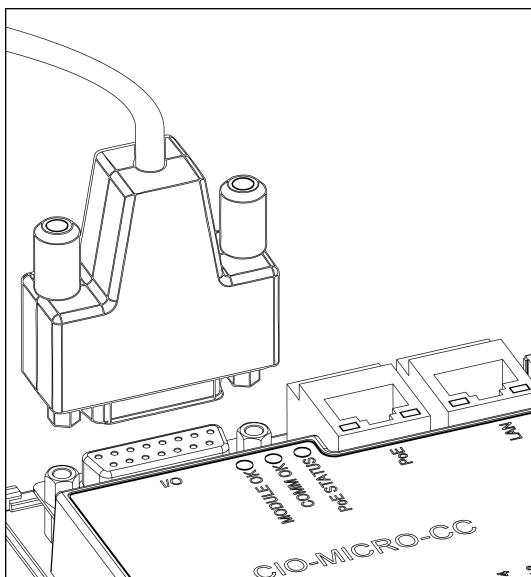

Connect the Ethernet and Power

The vision system's PoE connector provides the Ethernet connection for network communications and supplies power to the vision system. The following steps illustrate how to connect the In-Sight Micro vision system to the In-Sight CIO-MICRO or CIO-MICRO-CC I/O module. If neither I/O module is used, a third-party PoE injector or a PoE switch must be used to supply power to the vision system.

Note: For detailed connection information, see the *In-Sight® CIO-MICRO and CIO-MICRO-CC I/O Module Installation Manual*.

Connect the Power Wires

CAUTION: Never connect the I/O module to a power source other than 24VDC. Any other voltage creates a risk of fire or shock and can damage the hardware. Do not connect the 24VDC power source to any terminals other than the 24VDC + and – power terminals.

1. Verify that the 24 V DC power supply is unplugged and not receiving power.
2. Use a screwdriver to loosen the I/O module's power terminals (labeled 24VDC + and –).
3. Insert the 24VDC + and – wires (16 - 22 AWG, solid or stranded wire) from the power supply into the 24VDC + and – terminals on the I/O module.
4. Tighten the screw terminals with the screwdriver to secure the wire leads in the terminal block; the maximum torque is 0.1921 Nm (1.7 in-lb).

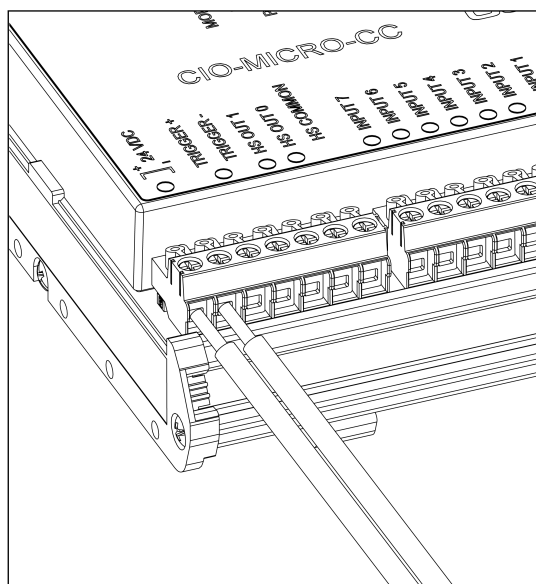

Connect the Frame Ground Wire

Connect a frame ground wire to the I/O module's Frame Ground terminal. Connect the other end of the frame ground wire to frame ground.

CAUTION: The shield ground connections of the RS-232 port, LAN port, PoE port, I/O port and Frame Ground terminal are internally connected. The system grounding is at a zero ground potential. This zero-ground potential extends through the cable and to peripheral equipment, such as a vision system or PLC. To ensure safe operating conditions, check ground connections to ensure that they meet a zero ground potential.

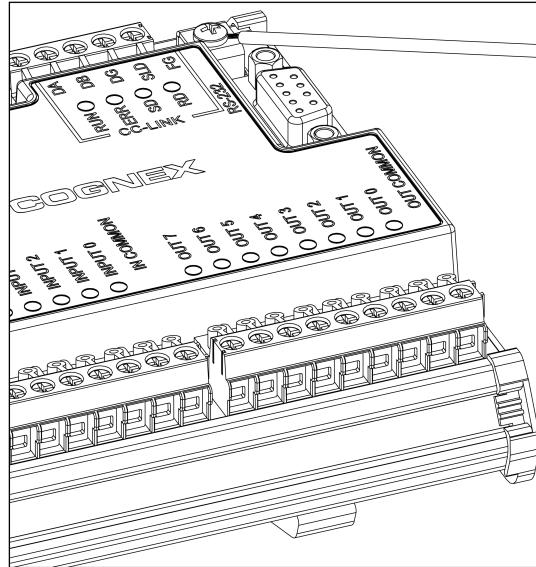

Connect an RJ-45 LAN Cable

To connect the vision system to an Ethernet network, plug a LAN cable (RJ-45 connector) into the I/O module's LAN port and connect the other end of the cable to a switch/router or PC, as applicable.

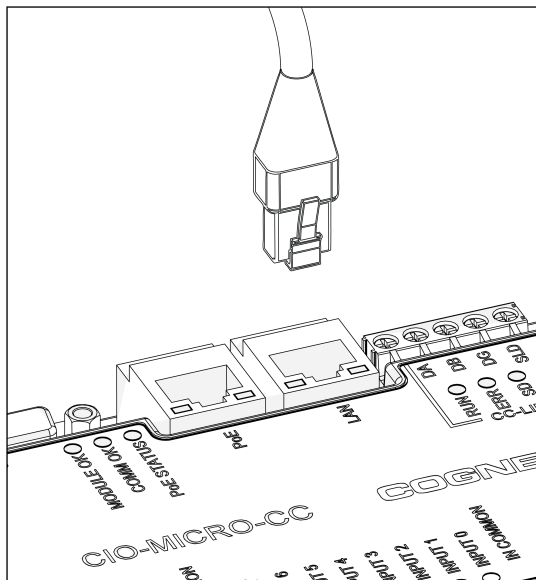

Connect the Ethernet Cable

CAUTION:

- All cable connectors are keyed to fit the connectors on the vision system. Do not force the connections or damage may occur.
- The I/O module's PoE port provides power and Ethernet connectivity to the In-Sight Micro vision system. If you connect third-party devices to the I/O module's PoE port, you could damage the I/O module.



1. Connect the Ethernet cable's M12 connector to the vision system PoE connector.

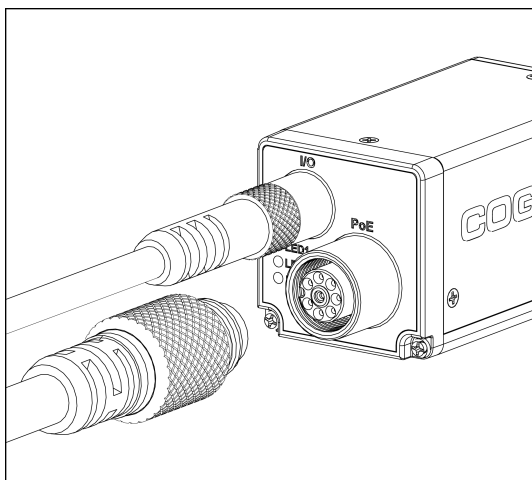

2. Connect the Ethernet cable's RJ-45 connector to the I/O module's PoE port.

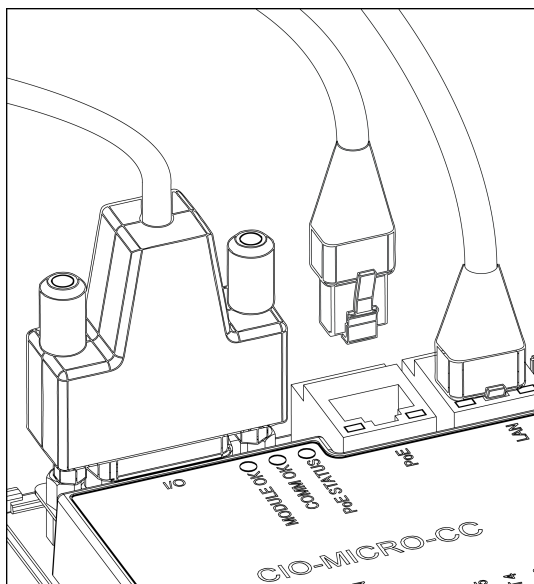

3. Restore power to the 24 V DC power supply and turn it on if necessary.

Specifications

The following sections list general specifications for the In-Sight Micro vision systems.

In-Sight Micro Vision System Specifications

Specifications	1020/1050	1100/1110	1100C	1400/1410	1400C	1402/1412	1403/1413	1403C	1500
Minimum Firmware Requirement	In-Sight version 4.4.3					In-Sight version 4.6.0	In-Sight version 4.4.3		In-Sight version 4.9.1
Job/Program Memory	128MB non-volatile flash memory; unlimited storage using a remote network device.								
Image Processing Memory	256MB SDRAM								
Sensor Type	1/3-inch CCD					1/1.8-inch CMOS	1/1.8-inch CCD		1/1.8-inch CMOS
Sensor Properties	5.92 mm diagonal, 7.4 x 7.4 μm sq. pixels					8.7 mm diagonal, 5.3 x 5.3 μm sq. pixels	8.8 mm diagonal, 4.4 x 4.4 μm sq. pixels		640 x 480: 4.24 mm diagonal, 5.3 x 5.3 μm sq. pixels
									800 x 600: 5.3 mm diagonal, 5.3 x 5.3 μm sq. pixels
Maximum Resolution (pixels) ¹	640 x 480					1280 x 1024	1600 x 1200		640 x 480
									800 x 600 ²
Electronic Shutter Speed	16 μs to 1000 ms					16 μs to 950 ms	52 μs to 1000 ms		640 x 480: 4 μs to 500 ms
									800 x 600: 5 μs to 500 ms
Acquisition	Rapid reset, progressive scan, full-frame integration.								

¹ You can configure the number of image sensor rows and set them in the In-Sight Explorer software. If you decrease the number of rows, it increases the frames per second acquired by the vision system. Refer to the AcquireImage topic in the *In-Sight® Explorer Help* file for more information.

² The default resolution for the In-Sight Micro 1500 vision system is 640 x 480 pixels. The vision system's resolution can be configured as 800 x 600 pixels within the In-Sight Explorer software. Refer to the *In-Sight® Explorer Help* file for more information.

Specifications	1020/1050	1100/1110	1100C	1400/1410	1400C	1402/1412	1403/1413	1403C	1500
Bit Depth	256 grey levels (8 bits/pixel)		24-bit color	256 grey levels (8 bits/pixel)	24-bit color	256 grey levels (8 bits/pixel)		24-bit color	256 grey levels (8 bits/pixel)
Frames Per Second ¹	60 full frames per second		58 full frames per second	60 full frames per second	58 full frames per second	60 full frames per second	14 full frames per second	7 full frames per second	640 x 480 resolution: 213 full frames per second 800 x 600 resolution: 157 full frames per second
Lens Type	CS-mount and C-mount (with 5 mm extension, included).								
Trigger	1 opto-isolated, acquisition trigger input. Remote software commands via Ethernet. (RS-232C available when using the optional CIO-MICRO or CIO-MICRO-CC I/O module.)								
Discrete Inputs	None. (Eight additional general-purpose inputs available when using the optional CIO-MICRO or CIO-MICRO-CC I/O module.)								
Discrete Outputs	2 opto-isolated, NPN/PNP high-speed outputs. (Eight additional general-purpose outputs available when using the optional CIO-MICRO or CIO-MICRO-CC I/O module.)								
Status LEDs	Network, 2 user-configurable.								
Network Communication	1 Ethernet port, 10/100 BaseT with auto MDI/MDIX. Supports DHCP (factory default), static and link-local IP address configuration.								
Serial Communication	None. (RS-232C: 4800 to 115, 200 baud rates when connected to the optional CIO-MICRO or CIO-MICRO-CC I/O module.)								
Power	Class 2 Power over Ethernet (PoE) device.								
Power Type	A and B.								
Power Consumption	6.49 W maximum per Class 2 PoE.								
Current	Per Class 2 PoE requirements.								
Voltage	48 V DC nominal, applied from a Class 2 PoE injector which is typically powered from some other voltage.								
Material	Die-cast zinc housing.								
Finish	Painted								
Mounting	Four M3 threaded mounting holes (1/4 - 20 and M6 mounting holes also available on mounting block).								
Dimensions	30 mm (1.18 in) x 30 mm (1.18 in) x 60 mm (2.36 in) without mounting block. 30 mm (1.18 in) x 38.2 mm (1.50 in) x 60 mm (2.36 in) with mounting block.								
Weight	121 g (4.27oz.) without mounting block. 146 g (5.15oz.) with mounting block.								
Temperature	Operating: 0°C to 45°C (32°F to 113°F) Storage: -30°C to 80°C (-22°F to 176°F)								
Humidity	90%, non-condensing (Operating and Storage)								

¹ Maximum frames per second are job-dependent, based on the minimum exposure for a full image frame capture using the dedicated acquisition trigger, and assumes there is no user interface connection to the vision system.

Specifications	1020/1050	1100/1110	1100C	1400/1410	1400C	1402/1412	1403/1413	1403C	1500
Protection	IP51 with cables and lens attached.								
Shock (Shipping and Storage)	80 G shock with 50 gram or lighter lens attached per IEC 68-2-27 EA.								
Vibration (Shipping and Storage)	10 G with 50 gram or lighter lens attached 2 hrs/axis (10-500 Hz) per IEC 68-2-6, FC.								
Regulatory Compliance	CE, FCC, KCC, TÜV SÜD NRTL, RoHS								

I/O Specifications

Cable and connector specifications and connection examples for the acquisition trigger input and the high-speed outputs are provided in the following sections.

Acquisition Trigger Input

The vision system features one acquisition trigger input, which is optically isolated. You can configure the acquisition trigger input to trigger from an NPN (current sinking) or PNP (current sourcing) device.

Specification	Description	
Voltage	ON: 20 to 28VDC (24VDC nominal) OFF: 0 to 3VDC (8VDC nominal threshold)	
Current	ON: 2.0 to 2.9mA OFF: < 250µA Resistance: ~10 kOhms	
Delay ¹	In-Sight Micro 1020, 1050, 1100, 1100C, 1110, 1400, 1400C, 1402, 1410, 1412 & 1500	63µs maximum latency between leading edge of trigger and start of acquisition. Input pulse should be minimum of 1 ms wide.
	In-Sight Micro 1403 & 1413	81µs maximum latency between leading edge of trigger and start of acquisition. Input pulse should be minimum of 1 ms wide.
	In-Sight Micro 1403C	116µs maximum latency between leading edge of trigger and start of acquisition. Input pulse should be minimum of 1 ms wide.

The Breakout cable can be used to trigger from an NPN photoelectric sensor or PLC output. Connect TRIGGER+ to +24VDC and connect TRIGGER- to the output of the photoelectric sensor. When the output turns ON, it pulls TRIGGER- down to 0VDC, turning the opto-coupler ON. For more information, refer to the [Breakout Cable Specifications on page 26](#).

The Breakout cable can also be used to trigger from a PNP photoelectric sensor or PLC output. Connect TRIGGER+ to the output of the photoelectric sensor and connect TRIGGER- to 0VDC. When the output turns ON, it pulls TRIGGER+ up to +24VDC, turning the opto-coupler ON. For more information, refer to the [Breakout Cable Specifications on page 26](#).

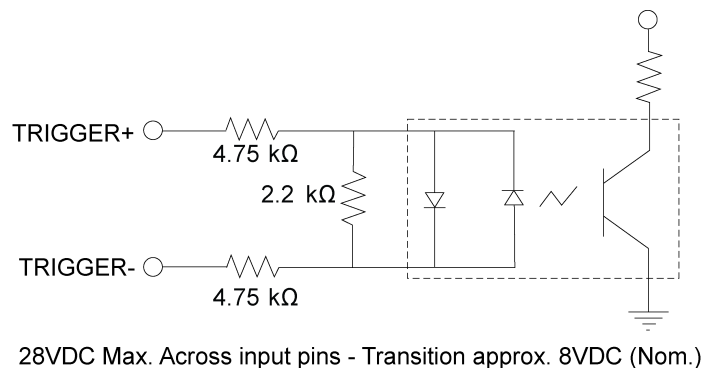

¹ Maximum latency is based on a 1µs trigger debounce.

High-Speed Outputs

The In-Sight Micro vision system features two built-in, high-speed outputs, which are optically isolated. The high-speed outputs can be used as either NPN (current sinking) or PNP (current sourcing) lines.

Specification	Description
Voltage	28VDC maximum through external load.
Current	100mA maximum sink current.
	OFF state leakage current 100µA maximum.
	External load resistance 240 Ohms to 10 kOhms.
	Each line rated at a maximum 100mA, protected against over-current, short circuit and transients from switching inductive loads. High current inductive loads require an external protection diode.
Delay ¹²	5µs (maximum due to opto-isolators turning ON).

For NPN lines, the external load should be connected between the output and the positive supply voltage (+24VDC nominal). HS COMMON should be connected to the negative supply voltage (0VDC). The outputs pull down to less than 3VDC when ON, which causes current to flow through the load. When the outputs are OFF, no current flows through the load.

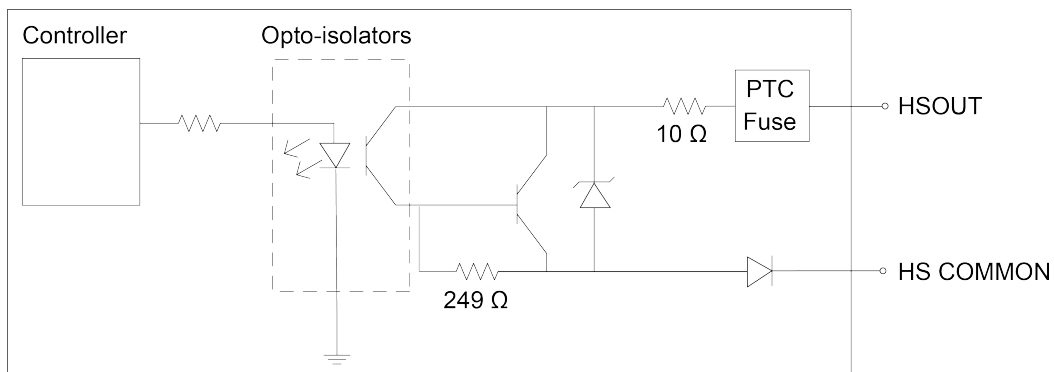

For PNP lines, the external load should be connected between the output and the negative supply voltage (0VDC). When HS COMMON is connected to the positive supply voltage (+24VDC nominal), the outputs pull up to greater than 21VDC when ON, and current flows through the load. When the outputs are OFF, no current flows through the load.

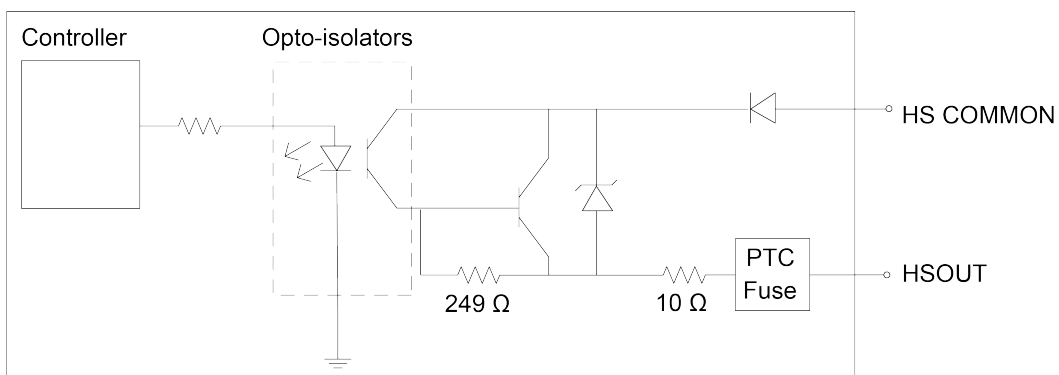

¹ Delay when opto-isolators turn OFF depends on the load to which the output is connected. With a 240 Ohm load, the maximum delay will be 35µs.

² If HSOUT 1 is configured as a Strobe output type within In-Sight Explorer, the maximum strobe latency is 5µs. For more information, refer to the *In-Sight® Explorer Help* file.

High-Speed Output - NPN Configuration

The Breakout cable can be used to connect to an NPN-compatible PLC input. Connect HSOUT 0 or HSOUT 1 directly to the PLC input. When enabled, the output pulls the PLC input down to less than 3VDC. For more information, refer to the [Breakout Cable Specifications on page 26](#).

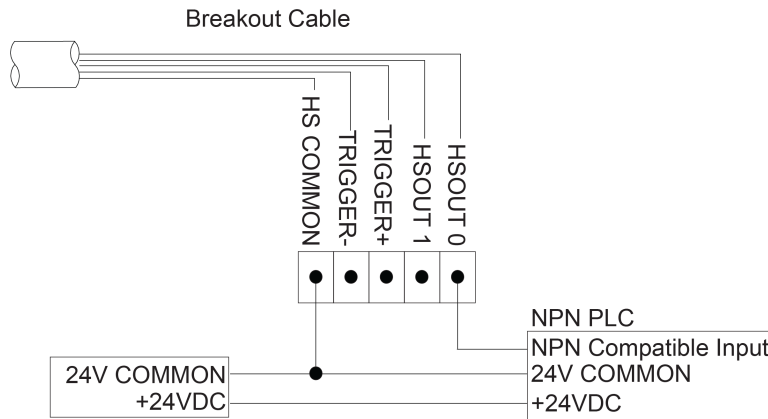

High-Speed Output - PNP Configuration

The Breakout cable can be used to connect to a PNP-compatible PLC input. Connect HSOUT 0 or HSOUT 1 directly to the PLC input. When enabled, the output pulls the PLC input up to greater than 21VDC. For more information, refer to the [Breakout Cable Specifications on page 26](#).

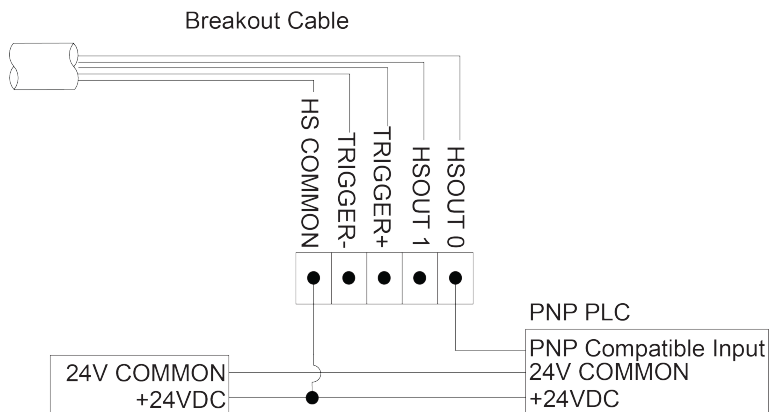

High-Speed Output - Relay/LED Configuration

The Breakout cable can be used to connect the high-speed outputs to a relay, LED or similar load. Connect the negative side of the load to the output and the positive side to +24VDC. When the output switches on, the negative side of the load is pulled down to less than 3VDC, and greater than 21VDC appears across the load. Use a protection diode for a large inductive load, with the anode connected to the output and the cathode connected to +24VDC. For more information, refer to the [Breakout Cable Specifications on page 26](#).

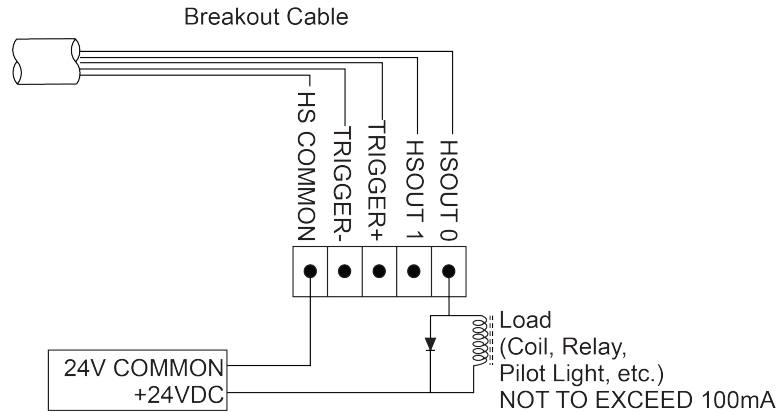

Ethernet Cable Specifications

The Ethernet cable provides the Ethernet connection for network communications and supplies power to the vision system.

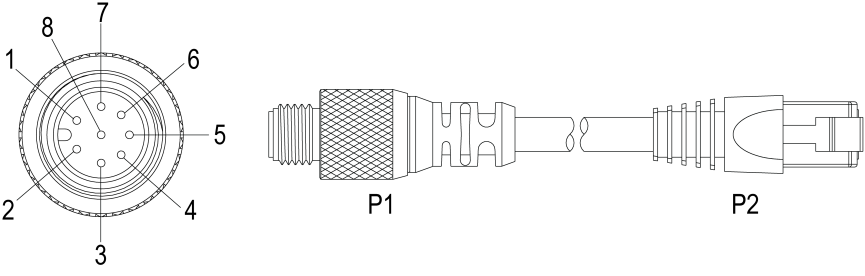

P1 Pin#	Signal Name	Wire Color	P2 Pin#
6	TPO+ / +48VDC (Mode A)	White/Orange	1
4	TPO- / +48VDC (Mode A)	Orange	2
5	TPI+ / +48VDC RTN (Mode A)	White/Green	3
7	+48VDC (Mode B)	Blue	4
1	+48VDC (Mode B)	White/Blue	5
8	TPI- / +48VDC RTN (Mode A)	Green	6
2	+48VDC RTN (Mode B)	White/Brown	7
3	+48VDC RTN (Mode B)	Brown	8

Note: Cables are sold separately.

Breakout Cable Specifications

The Breakout cable provides access to the vision system’s trigger and high-speed outputs. The Breakout cable can be connected to devices, such as a PLC, trigger sensor or strobe light. The Breakout cable is not terminated.

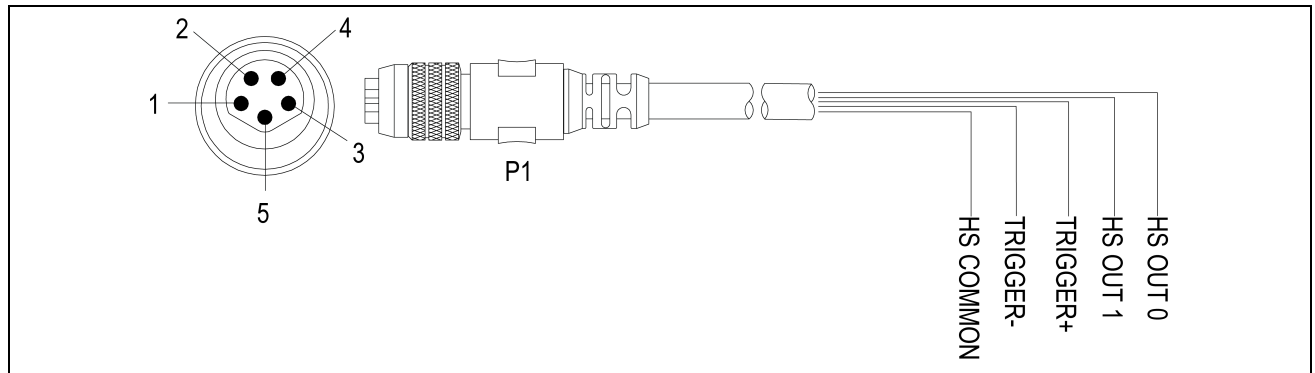

P1 Pin#	Signal	Wire Color
1	HSOUT 0	Brown
2	HSOUT 1	White
3	TRIGGER+	Blue
4	TRIGGER-	Black
5	HS COMMON	Gray

Note:



- Cables are sold separately.
- You can clip unused wires short or use a tie made of non-conductive material to tie them back.

I/O Module Cable Specifications

The I/O Module cable is used with the CIO-MICRO or CIO-MICRO-CC I/O module. The I/O Module cable connects the vision system directly to the I/O module via the DB15 connector. When connected, the I/O Module cable provides access to the vision system's trigger and high-speed outputs.

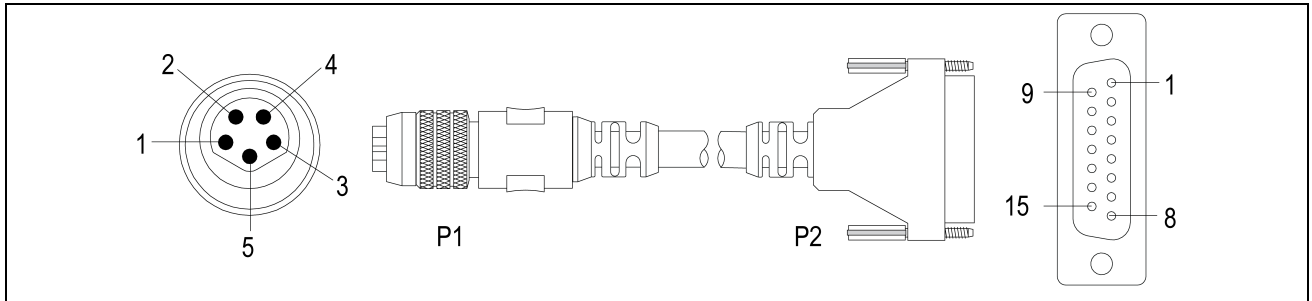

P1 Pin#	Signal Name	P2 Pin#
1	HSOUT 0	4
2	HSOUT 1	5
3	TRIGGER+	2
4	TRIGGER-	3
5	HS COMMON	15

Note:



- Cables are sold separately.
- For detailed connection information, see the *In-Sight® CIO-MICRO and CIO-MICRO-CC I/O Module Installation Manual*.

Dimensions

The following sections list dimensions of the vision system and optional accessories.

Vision System Dimensions

Note:



- Dimensions are in millimeters [inches] and are for reference purposes only.
- All specifications are for reference purposes only and can change without notice.

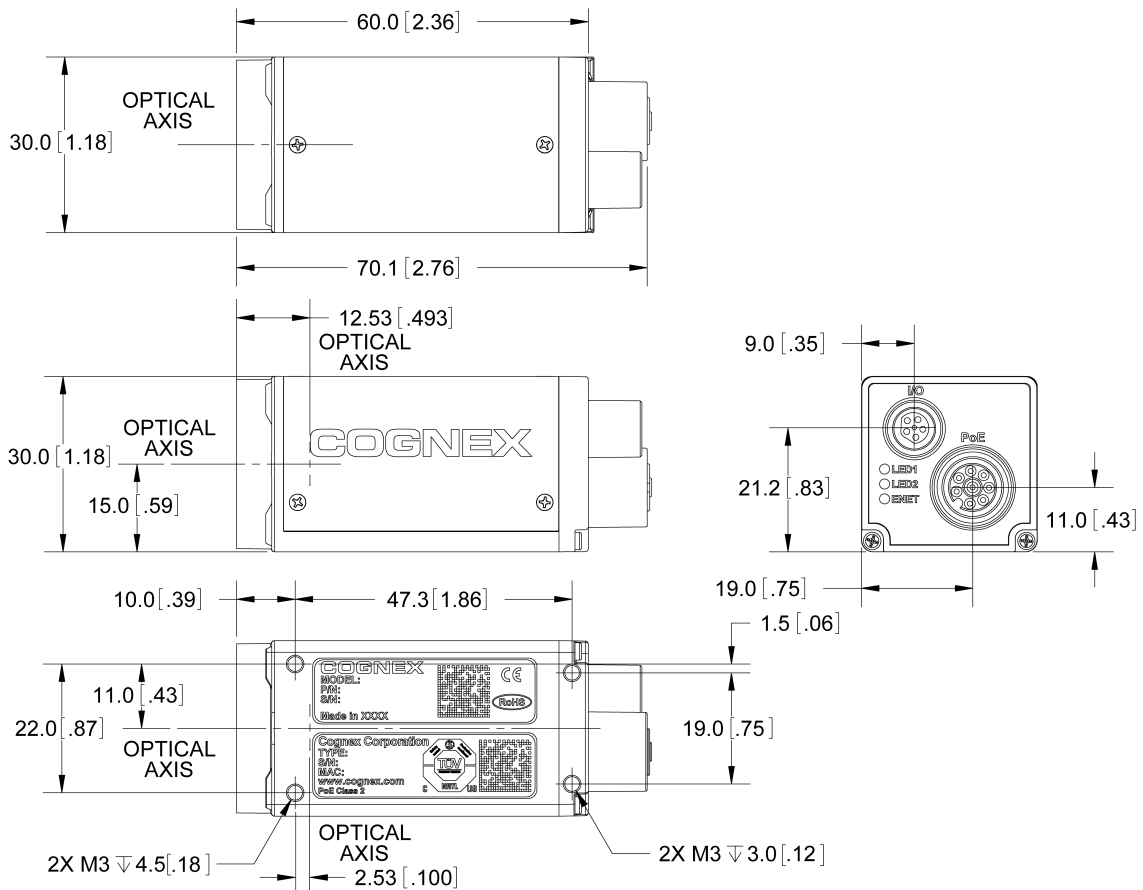

Vision System Dimensions (with Mounting Block)

Note:



- Dimensions are in millimeters [inches] and are for reference purposes only.
- All specifications are for reference purposes only and can change without notice.

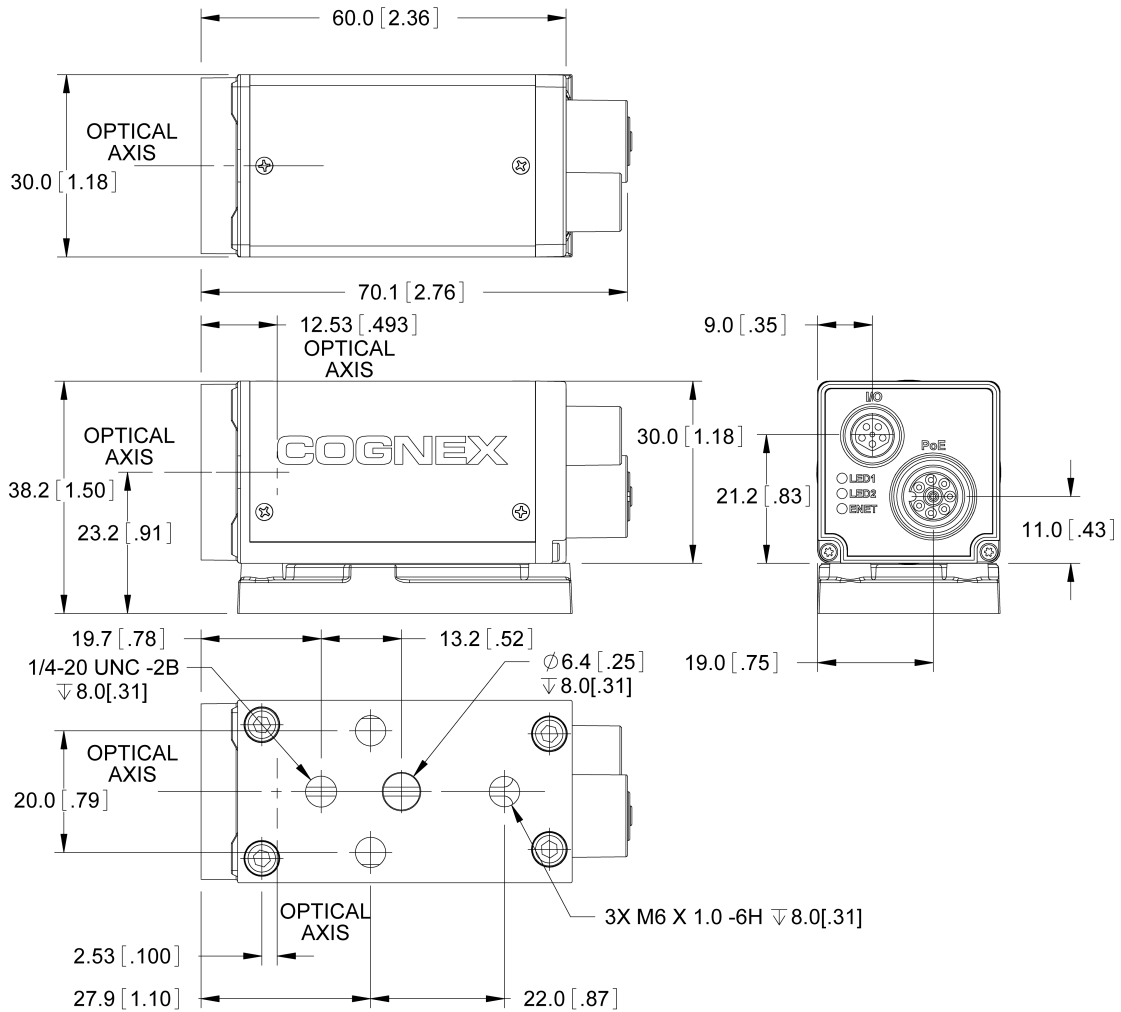

Appendix A - Cleaning and Maintenance

Clean the Vision System Housing

To clean the outside of the vision system housing, use a small amount of mild detergent cleaner or isopropyl alcohol on a cleaning cloth. Do not pour the cleaner on the vision system housing.

 **CAUTION:** Do not attempt to clean any DataMan product with harsh or corrosive solvents, including lye, methyl ethyl ketone (MEK) or gasoline.

Clean the Vision System Image Sensor Window

To remove dust from the outside of the image sensor window, use a pressurized air duster. The air must be free of oil, moisture or other contaminants that could remain on the glass and possibly degrade the image. Do not touch the glass window. If oil or smudges remain, use a cotton bud and alcohol (ethyl, methyl, or isopropyl) to clean the window. Do not pour the alcohol on the window.

