

## ADVANTAGE ENGINE WITH I/O BOARD | VISION AND BARCODE READING

Embedded Image Engine | OEM Smart Camera

- Powerful and reliable vision and identification tools from the industry leader in machine vision technology
- Best-in-class 1D and 2D code reading
- Easy and powerful application development software
- Flexible optics
- Exceptionally compact design



The Cognex Advantage™ engine products offer original equipment manufacturers (OEMs) the ability to leverage the power of Cognex vision and barcode reading tools in a product that is exceptionally compact and flexible, but also cost effective. The Advantage OEM product family from Cognex delivers best-in-class 1D and 2D code reading, plus a full suite of industry-proven vision tools to locate, analyze and inspect parts or features. The Advantage engines include proven, easy-to-use application software and are designed for deep integration into OEM products.

### Solve the Most Challenging Applications

Cognex industry-proven vision tools can locate, inspect and analyze parts accurately and reliably. Whether the application is to identify the pattern of a part, count objects, read text (OCR), read a barcode or measure distances, Cognex Advantage engines provide OEMs with a reliable and easy-to-implement solution.

### Read the Most Challenging Codes

Cognex is the leader in industrial barcode reading technology and the Advantage engines benefit from our market leadership and experience. Advantage engines include the advanced 1DMax® with Hotbars® and 2DMax® code reading algorithms allowing them to read the most difficult codes. Cognex code reading technology provides superior performance even on codes with scratches, voids, low contrast, rotation or specular reflection.

### Flexible Integration, Optics and Communications

The Advantage engines allow maximum flexibility for OEMs to custom design Cognex smart camera technology into their product. The Advantage engines provide two communication options—connect, communicate and transfer images via Ethernet or send data with RS-232. The Advantage engines can be integrated with the standard Cognex I/O board with a RJ-45 connection for Ethernet and a cable with DB-15 connector for power, I/O and RS-232 communication.

The modular lens design provides the ability to use different lenses for optimal working distance and field-of-view requirements. Plus, the built-in illumination to simplifies integration requirements.

### Simple Application Development Software

Advantage engines include easy-to-use Cognex application software to quickly test and develop the vision and barcode reading tools needed for specific requirements. Cognex software and vision tools provide unmatched flexibility, ease of use and control.

## SPECIFICATIONS

Dimensions	14.5 mm (H) x 29.1 mm (W) x 20.5 mm (L)
Weight	9.5 g (21 g with I/O board)
Power	4.5 to 5.5 VDC (2.5 W maximum)
Operating temperature	0 °C to 40 °C (32 °F to 104 °F)
Illumination	Integrated red LED illumination
Imager	AE2: 752 x 480, 1/3 inch b/w CMOS AE3: 1280 x 960, 1/3 inch b/w CMOS AE3C: 1280 x 960, 1/3 inch color CMOS
Optics	M12 6.2 mm f/5 3-focal position lens standard Optional lenses: 3.5 mm f/6, 6.2 mm f/10, 8 mm f/2, 10.2 mm f/5, 16 mm f/7, 25 mm f/2
Communication	Ethernet 10/100 (configuration plus data and image output) RS-232 (data output)
Connections	Without I/O board: 31-pin ZIF connector With I/O board: RJ-45: Ethernet DB15 or USB-C: power, I/O and serial
Inputs	2 digital (1 general purpose, 1 trigger, 3.3 V LV TTL)
Outputs	3 digital (2 general purpose, 1 external strobe, 3.3 V LV TTL)
Environmental	RoHS- and WEEE-compliant humidity: 95% (non-condensing)
Symbologies	2D: DataMatrix, QR Code; 1D: Code 128, Code 39, Interleaved 2 of 5, Pharmacode, UPC, EAN, Code 93, Codabar, GS1-128, POSTNET, PLANET, Japan Post, Australia Post, UPU, USPS OneCode; Composite: PDF417, Micro PDF417, GS1/Databar
Vision and barcode reading tools (partial list)	1DMax with Hotbars, 2DMax, PatMax®, PatQuick®, normalized correlation, edge, caliper, geometry tools, blob, histogram, OCR, OCV, image filtering tools

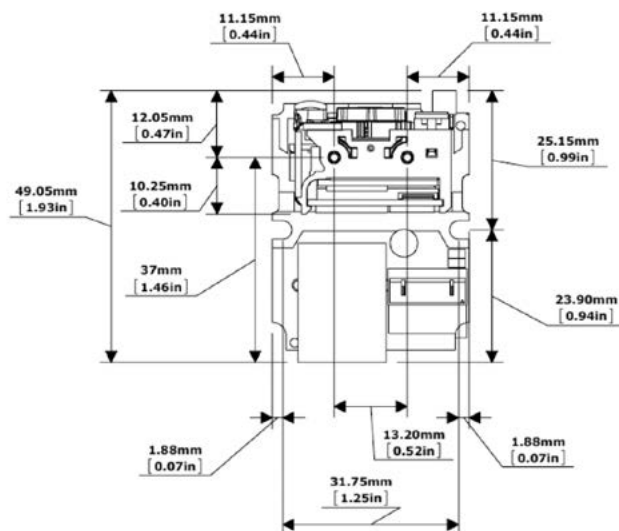
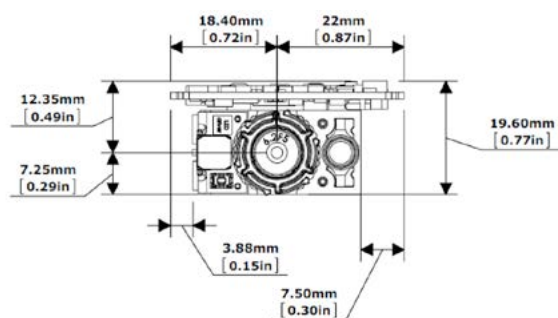
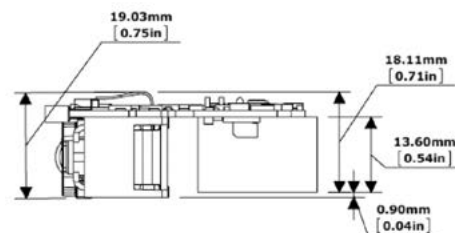

# COGNEX

Companies around the world rely on Cognex vision and barcode reading solutions to optimize quality, drive down costs and control traceability.

Corporate Headquarters One Vision Drive Natick, MA 01760 USA

### Regional Sales Offices

#### Americas

North America +1 844-999-2469  
Brazil +55 (11) 2626 7301  
Mexico +01 800 733 4116

#### Europe

Austria +49 721 958 8052  
Belgium +32 289 370 75  
France +33 1 7654 9318  
Germany +49 721 958 8052

Hungary +36 800 80291  
Ireland +44 121 29 65 163  
Italy +39 02 3057 8196  
Netherlands +31 207 941 398  
Poland +48 717 121 086  
Spain +34 93 299 28 14  
Sweden +46 21 14 55 88  
Switzerland +41 445 788 877  
Turkey +90 216 900 1696  
United Kingdom +44 121 29 65 163

#### Asia

China +86 21 6208 1133  
India +9120 4014 7840  
Japan +81 3 5977 5400  
Korea +82 2 539 9980  
Malaysia +6019 916 5532  
Singapore +65 632 55 700  
Taiwan +886 3 578 0060  
Thailand +66 88 7978924  
Vietnam +84 2444 583358

© Copyright 2019, Cognex Corporation. All information in this document is subject to change without notice. All Rights Reserved. Cognex, 1DMax, Hotbars, 2DMax, PatMax and PatQuick are registered trademarks of Cognex Corporation. Advantage is a trademark of Cognex Corporation. All other trademarks are property of their respective owners. Lit. No. DSAE2VID-04-2019

[www.cognex.com](http://www.cognex.com)